

# Dutchess

**Bakers' Machinery Company, Inc.**

*A subsidiary of Superior-Lidgerwood-Mundy Corp.*

*A United States of America Manufacturer Since 1886*

Item No. \_\_\_\_\_

## **MODEL SDR-4 / SDR-4FL**

Side Operated / Front Operated  
SINGLE-PASS DOUGH ROLLERS

**Features synthetic rollers that reduce dough build up making it easier to clean. An ideal roller for any food service operation.**

### **STANDARD FEATURES:**

- ~ Sheet round or rectangular shapes for pizza, cinnamon rolls, pies, etc. up to 18" wide in just seconds.
- ~ Front and side load models to meet your needs.
- ~ Indexed precision machined synthetic rollers have fast, positive repeat adjustments in just seconds.
- ~ Dough stops allow for presetting two-pass operation.
- ~ Safety interlock automatically shuts off machine when panel is removed for cleaning or service.
- ~ Synthetic roller material is sanitary and easy to clean with mild soap and water. It also reduces dough adhesion and buildup.
- ~ All mechanical parts, chains, etc. are located away from flour and dough areas.
- ~ Low profile design.
- ~ White powder coated finish. Heavy-duty welded steel construction.
- ~ NSF, UL Listed, meets OSHA requirements.
- ~ Economical price.

### **OPTIONS:**

- ~ Choice of Chrome Plated or Synthetic Rollers

 **NSF** (National Sanitation Foundation)

 **UL** (Underwriters Laboratories)



**SDR-4 Side load operation**

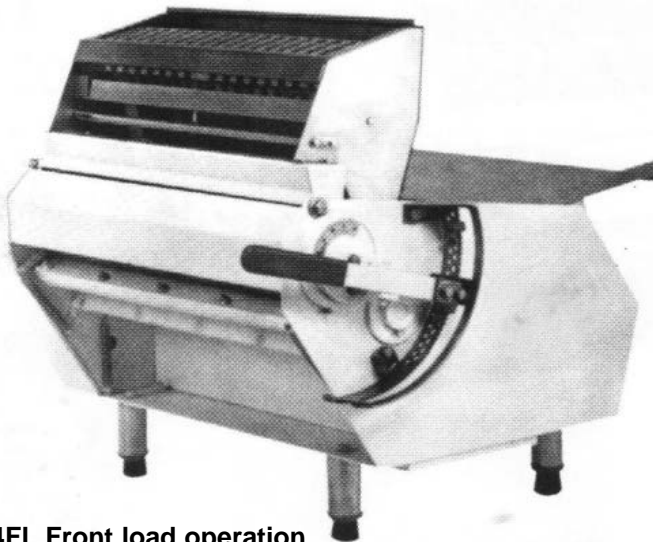

**SDR-4FL Front load operation**

ASSOCIATE MEMBER  
**MAFSI**  
Manufacturers' Agents for  
the Food Service Industry

**Dutchess Bakers' Machinery Co.**  
302 Grand Avenue, PO Box 39  
Superior, WI 54880

**ISO 9000:2001 COMPLIANT**

Toll Free: 800-777-4498  
Phone: 715-394-4444  
Fax: 715-394-2406  
sales@dutchessbakers.com  
www.dutchessbakers.com

# SDR-4 Side Operated Single-Pass Dough Roller SDR-4FL Front Loading Single-Pass Dough Roller

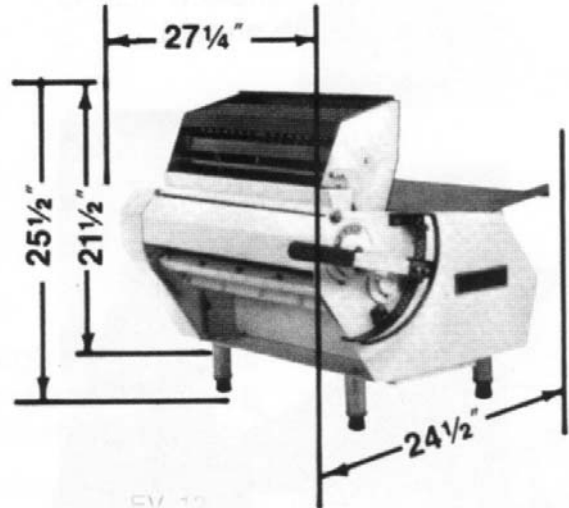
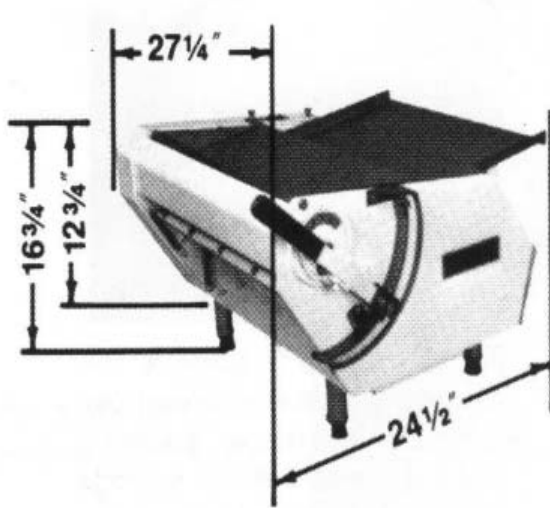

**Machine Dimensions:**

**Width:** 27.25" **Length:** 24.5" (overall) **Height:** SDR-4 16.75" ~ SDR-4FL 25.5"  
**Shipping Wt.:** SDR-4 = 200lbs, SDR-4FL 220lbs **Shipping Class:** 85 **FOB:** 60062  
**Shipping Dimensions:** SDR-4 16-3/4" x 27-1/4" x 24.5" ~ SDR-4FL 25.5" x 24.25" x 24.5"  
**Counter Space required:** 28"w x 20"d (approximate)

**Electrical requirements:**

**Standard:** 115v / 60hz / 1-phase, 1/2 motor, 7 amps, 6' - 3 wire cord and plug  
**Optional electrical:** Call for details  
**Stop/Start Switch:** Heavy Duty Type (sealed with clear rubber boot)

**Specifications:**

	<b>SDR-4</b> (Side-operation)	<b>SDR-4FL</b> (Front operation)
<b>Roller Material:</b>	Synthetic or Chrome	Synthetic or Chrome
<b>Roller Speed:</b>	85 fpm @ 60 hz	85 fpm @ 60 hz
<b>Roller Size:</b>	3-1/2" dia. x 20" lg.	3-1/2" dia. x 20" lg.
<b>Roller Quantity:</b>	2	2
<b>Quick Set Roller Adj.:</b>	Standard	Standard
<b>Ball Bearings:</b>	Sealed	Sealed
<b>Infeed Pan &amp; Guard:</b>	Stainless Steel	Stainless Steel and Aluminum
<b>Flour Pan:</b>	Stainless Steel	n/a
<b>Dough Chute:</b>	n/a	Stainless Steel and Aluminum
<b>Legs:</b>	4" sanitary adjustable	4" sanitary adjustable

**Certifications:** NSF, UL, meets OSHA requirements  
 Easy to remove polyethylene scrapers

**Standard:** FDA Approved White Powder Coated Finish  
**Options:** Chrome Rollers, 50hz Electrical (call for availability)

Dutchess Bakers' Machinery Company Inc., 302 Grand Avenue, Superior, WI 54880-0039  
 Toll Free: 800-777-4498 ~ Ph: 715-394-4444 ~ Fax: 715-394-2406  
 sales@dutchessbakers.com ~ www.dutchessbakers.com