

Dutchess

Bakers' Machinery Company, Inc.

A subsidiary of Superior-Lidgerwood-Mundy Corp

Item No.

Model DUT/V-60

60 Quart Floor Model Mixer



Standard Features:

- ◆ Heavy Duty 2 HP Motor
- ◆ 208/240/60/1 or 3
- ◆ # 12 Attachment Hub
- ◆ Gear Driven Transmission
- ◆ 3-Speed with 30-Minute Timer w/Auto Shut-off
- ◆ Safety Bowl Guard
- ◆ Bowl Lift Safety
- ◆ Manual Bowl Lift
- ◆ Dough Hook
- ◆ Wire Whip
- ◆ Beater Paddle
- ◆ Stainless Steel Bowl
- ◆ Bowl Locking Handles
- ◆ 3-yr Limited Parts Warranty
- ◆ 1 Year Full Parts & Labor Warranty



Dutchess Bakers' Machinery Company

302 Grand Avenue, PO Box 39

Toll Free: 800-777-4498

Phone: 715-394-4444

E-mail: sales@dutchessbakers.com

Web: www.dutchessbakers.com

Model DUT/V-60 Floor Model Planetary Mixer

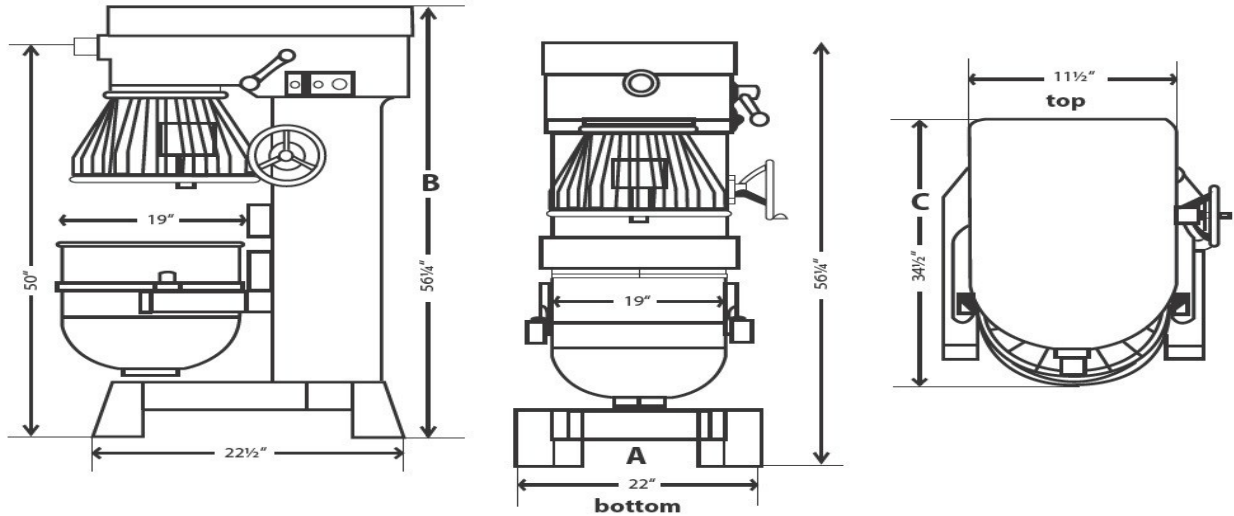

Electrical:

2 hp Heavy Duty Motor 220 / 60 hz / 3-phase, 7.5-Amp

- or -

2 hp Heavy Duty Motor 220/240 / 60 / 1-phase, 16.9-Amp

Manual Reset Motor Overload - Auto Shut-Off when Bowl is Lowered or Bowl Guard Opened.

Dimensions:

22" Wide x 56.25" High x 34.5" Depth

Weight:

814 lbs. Net Weight, 940 lbs Shipping Weight.

Speed	Agitator RPM's	Attachment Hub RPM's
1	104	119
2	197	226
3	331	380

Warranty:

- ◆ 3-Year Limited Parts
- ◆ 1-Year Standard Parts and Labor

DUTCHESS BAKERS' MACHINERY COMPANY, INC. 302 GRAND AVENUE, SUPERIOR, WI 54880-0039

TOLL FREE: 800-777-4498 - PH: 715-394-4444 - FAX: 715-394-2406